



KIT PART NUMBER 6230100

INSTRUCTIONS TO REPLACE THE INFRARED MUG SENSOR ON A HOT DRINK CENTER OR EURO-DRINK MERCHANDISER WITH A TRANSMISSIVE MUG SENSOR

CHECK THE PARTS RECEIVED IN THE KIT WITH THE PARTS LIST IN THESE INSTRUCTIONS. IF ANY PARTS ARE MISSING, CONTACT THE NATIONAL VENDORS PARTS DEPARTMENT IMMEDIATELY.

Read these instructions carefully before installing the kit.
Keep these instructions for part numbers and for future reference.

This kit contains the following:

INDEX	PART NUMBER	DESCRIPTION	QUANTITY
1	6231540	MUG SENSOR & BRKT. ASSY TRANSMISSIVE	1
2	6231558	BRACKET, LED	1
3	9989642	LENS, LED	2
4	9989644	SPACER, LED LENS	2
5	9989643	LED LOCKING RING	2
6	9989641	CAPLUG 3/8 FLUSH TYPE	1
7	6230101	KIT INSTRUCTIONS	1
8	1451097	SCREW TY 6-32 X .31 HEX HD TF BLK	2
9	2342315	CLIP - WIRE HARNESS	2

Proceed as follows:

1. Remove the cup delivery assembly from the machine (figure 1).
2. Disconnect the wiring harness from the infrared cup sensor assembly (if installed), and remove the infrared cup sensor from the machine (figure 2). Keep mounting screws for later use.
3. Install the mug sensor and bracket assembly, transmissive (1), and the LED bracket (2) onto the cup station support assembly as shown (figure 3). Use the mounting screws left over from step 2.
4. Install the emitter LED and detector phototransistor into the LED bracket (2) as shown (figure 4):
 - a. Press one lens (3) into each side of the LED bracket (2).
 - b. Press a spacer (4) onto each lens (3).
 - c. Insert the LED into the lens (3) on the left. Insert the phototransistor into the lens (3) on the right. Fit the phototransistor tab into one of the slots on the lens.
 - d. Press the LED locking ring (5) onto the lens, locking the LED in place.
 - e. Capture the LED wires with the wire harness clips (9), and attach the clips to the LED bracket (2) using two screws (8).



-
5. Cut out and fold the templates as indicated. Place the left side template on the left side of the cup delivery assembly as shown (figure 5). Drill a 0.75" (1.9 cm) hole in the side of the cup delivery assembly as indicated on the template. Repeat this procedure for the right side of the cup delivery assembly, using the right side template.
 6. Install the cup delivery assembly into the machine. Make sure nothing is blocking the emitter and detector from each other.
 7. Test the mug sensor:
 - a. Turn the power to the machine ON.
 - b. With no mug or other object blocking the light beam, the red LED on the right side of the mug sensor and bracket assembly (see figure 3) should not be lit. If the LED is lit, adjust the sensitivity control (through the hole at the back of the mug sensor and bracket assembly) until the LED is off.
 - c. Place a test mug into the cup delivery assembly and observe that the LED turns ON. Again, adjust the sensitivity control as necessary.
 - d. When all tests and adjustments are complete, place the caplug (6) into the hole in the rear of the mug sensor and bracket assembly. This will help prevent moisture and liquids from entering the assembly housing.

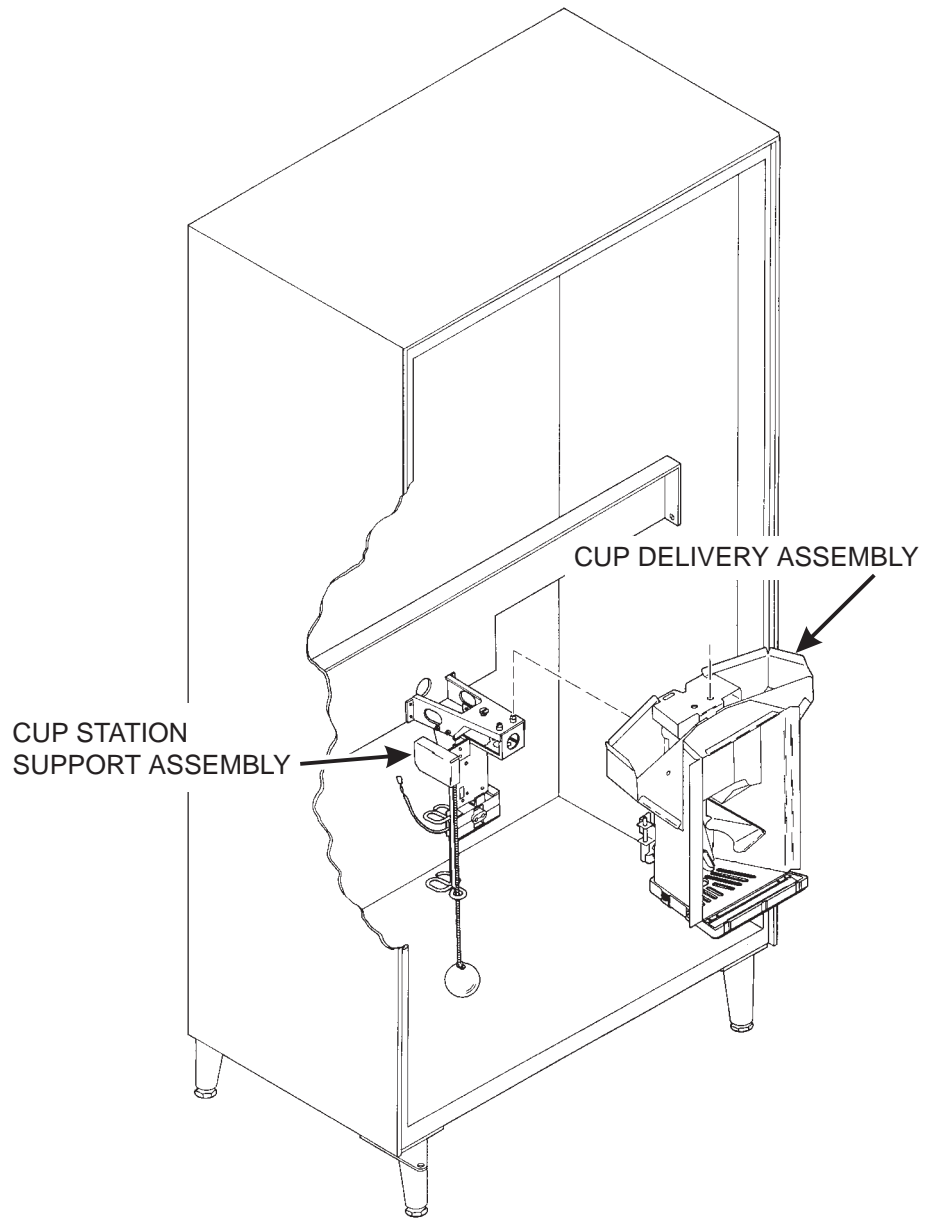

Figure 1

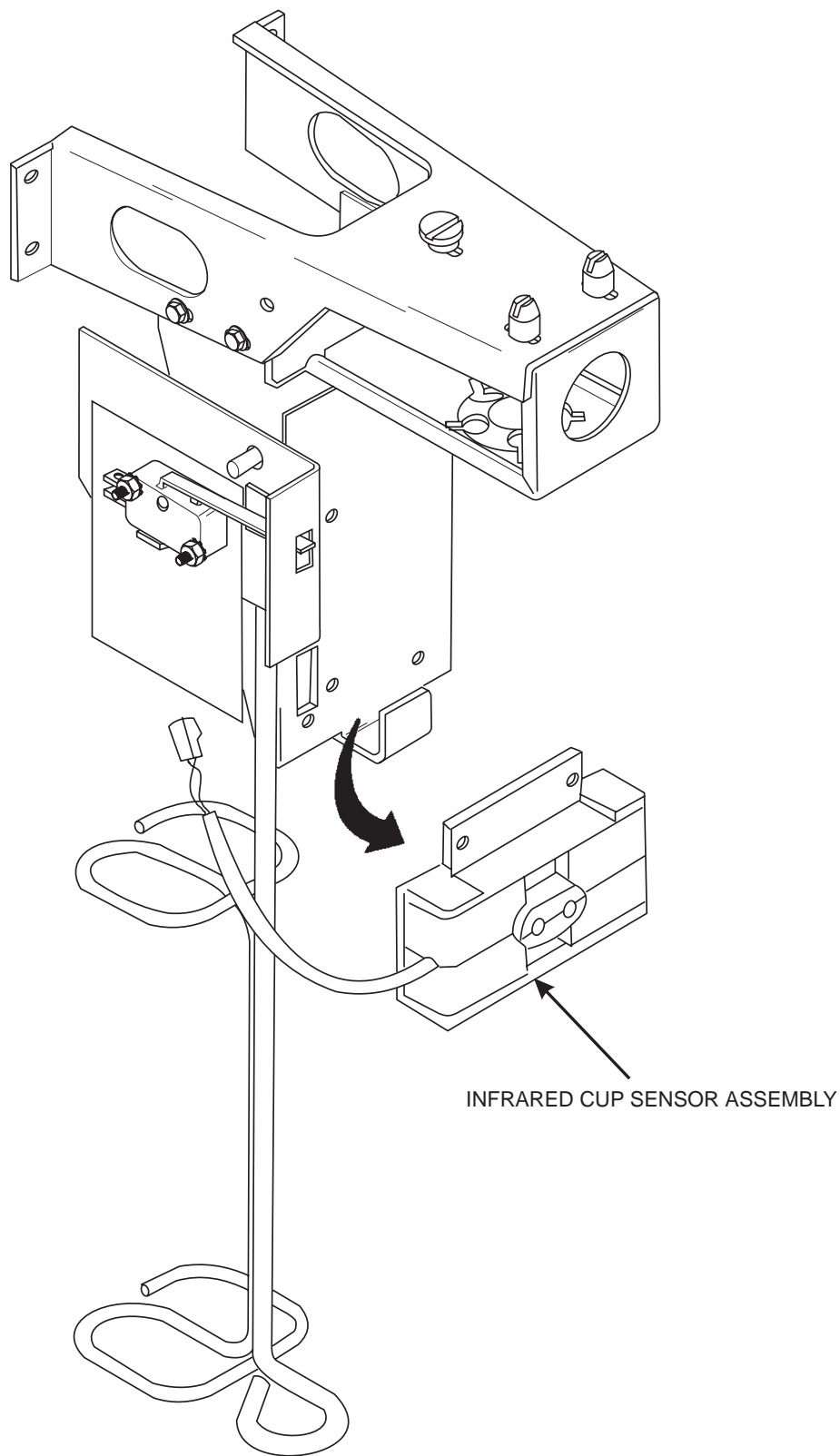

Figure 2.

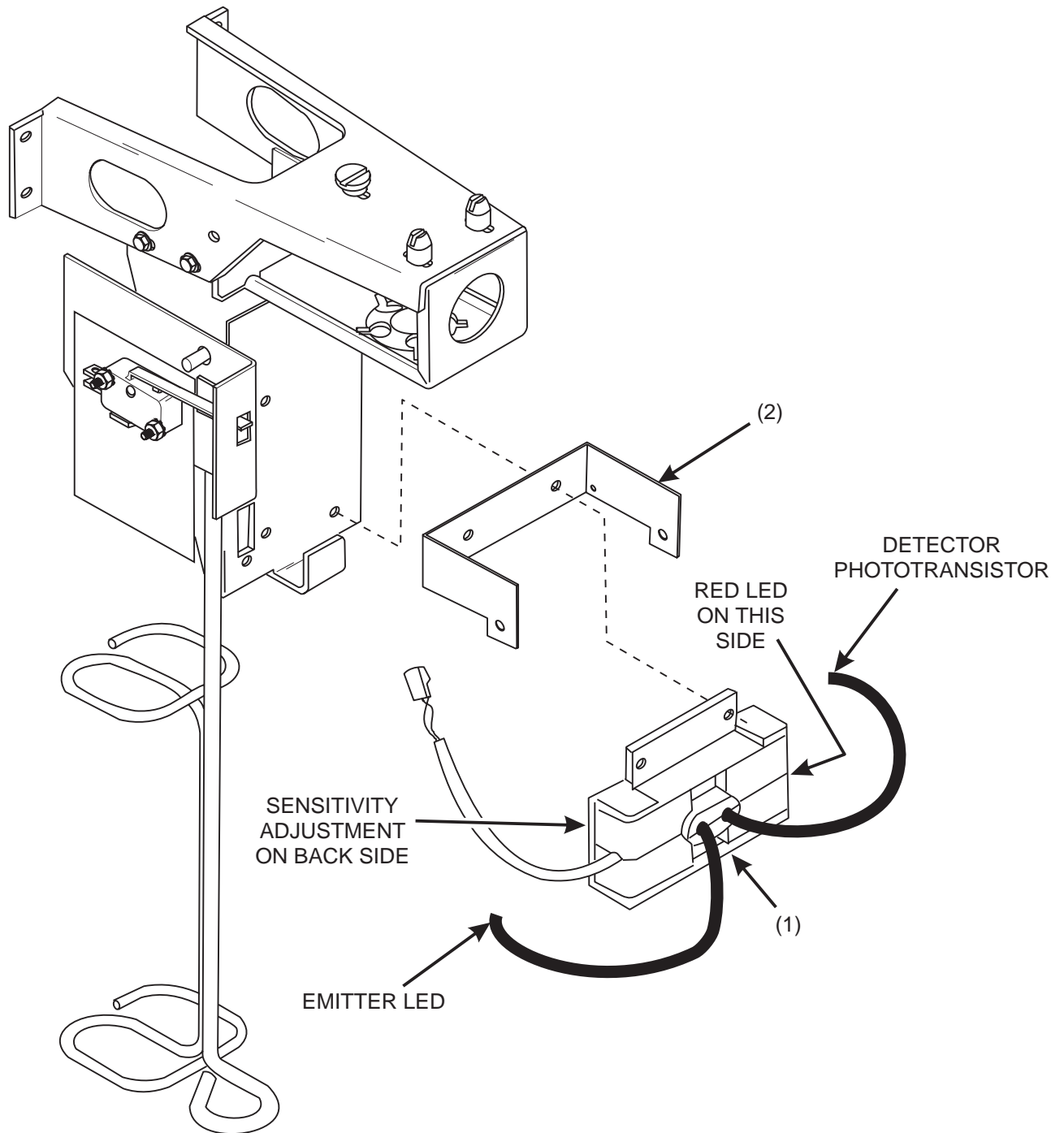

Figure 3

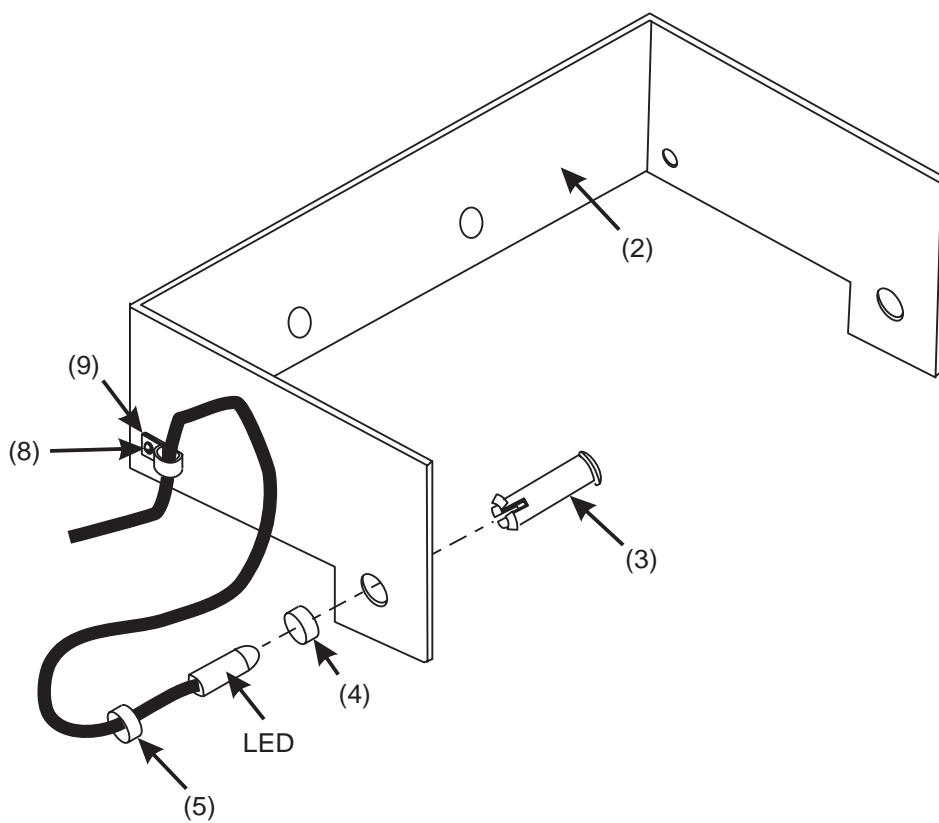

Figure 4

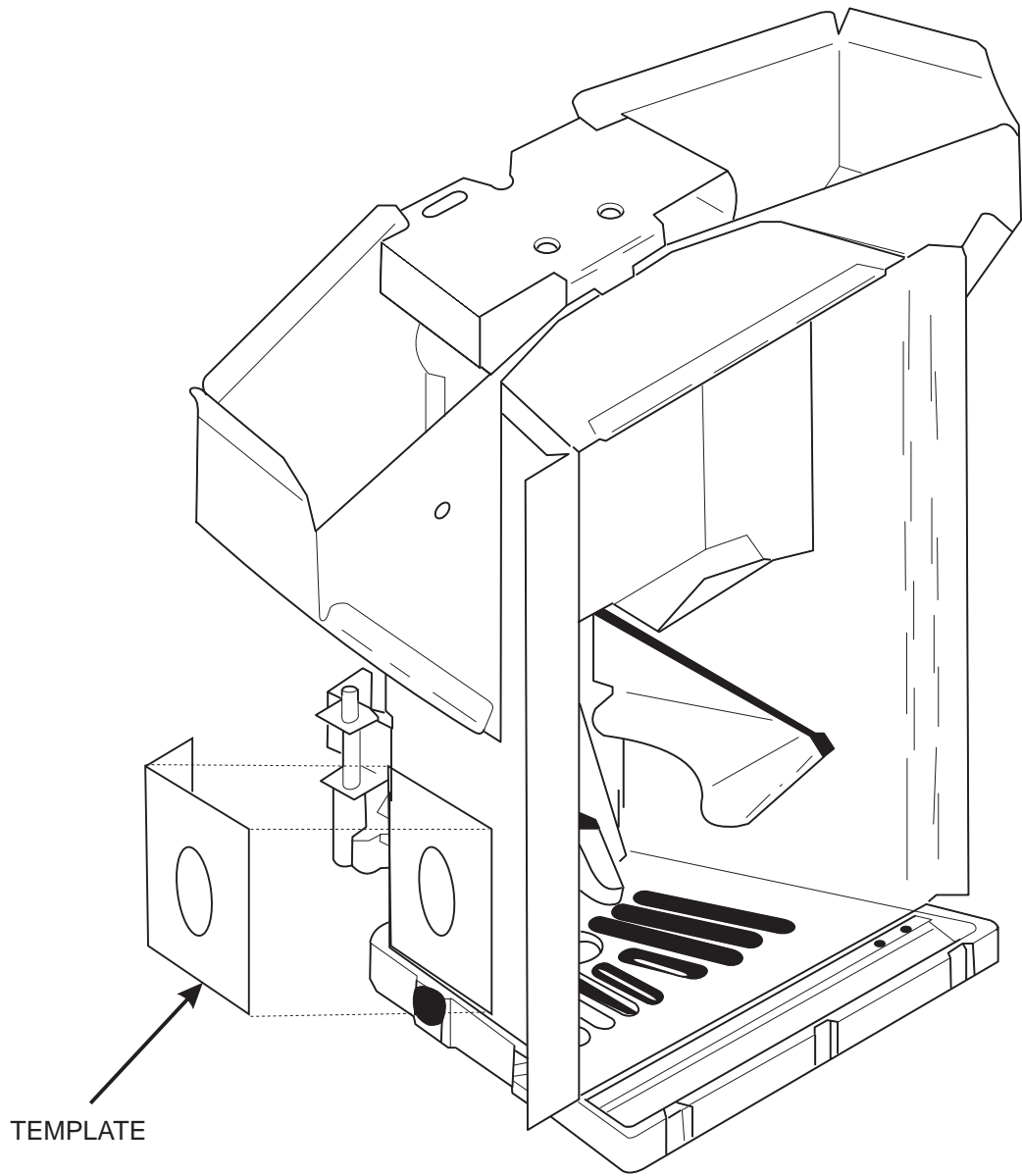
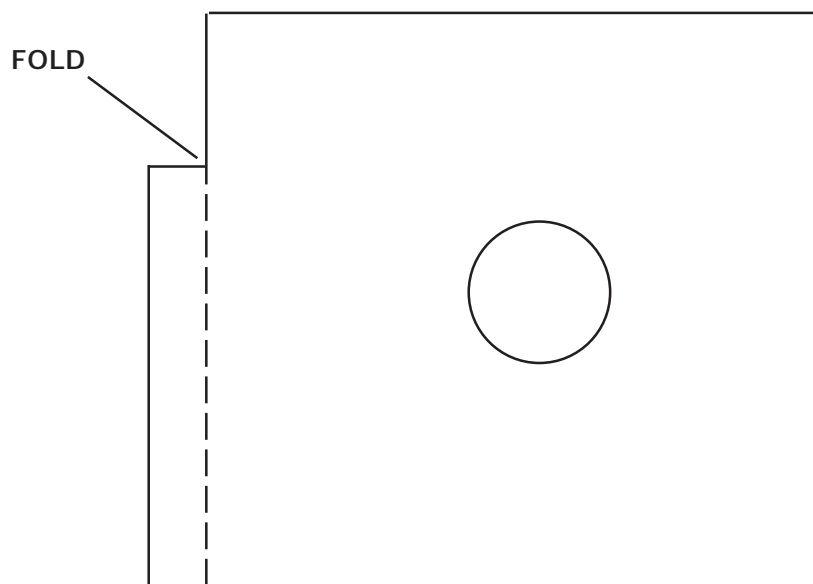

Figure 5.



LEFT SIDE TEMPLATE



RIGHT SIDE TEMPLATE

